

9120
THE REVOLUTION
SERIES

THE REVOLUTION
Faster, Better
Smarter

BRK 9120 Series Alarms Introduction and Frequently Asked Questions



9120B



SC9120B



SA9121

Introduction

Introducing the *Revolutionary* 9120 Series smoke alarms and smoke & carbon monoxide combination alarms from BRK. They have been redesigned from the ground up. They install faster, perform better and are even smarter than before. All of these improvements help reduce nuisance alarms and save the Contractor time and money.

For over 40 years, BRK has always maintained our commitment to building the absolute best in home-safety products. The 4120 Series changed the industry in 1998 with contractor preferred features such as a side load battery drawer, battery pull tab and a sleek, low profile design. Now, the new 9120 Series with its new look, "Perfect Mount" gasketless base and Smart Technology all make this alarm the best we have ever developed. We asked you how we could make our alarms better, we listened to what you had to say and we designed our products with you, the professional in mind. The 9120 Series is a Smarter Choice...
Let the Revolution begin.



SMOKE ALARMS CO ALARMS HEAT ALARMS FIRE EXTINGUISHERS



THE REVOLUTION

Faster, Better Smarter

BRK 9120 Series Alarms Introduction and Frequently Asked Questions

Question: What's new?

Answer: **New Look:** The alarm's new look now more closely matches the CO alarms in the BRK line. This provides a consistent look throughout the home. The Smoke/CO combo alarms are prominently marked with contrasting text to clearly identify CO alarms from smoke alarms in the house.

Smart Technology System designed to help reduce unwanted or nuisance alarms

Single Button Test/Silence eliminates confusion. Depending on what mode the alarm is in, pushing the button provides different functions such as testing the alarm, silencing the alarm, re-testing the alarm when in silence and clearing the Latching feature.

Latching Alarm Indicator easily identifies initiating alarm even after the alarm condition has subsided. Provides easy troubleshooting for improved homeowner satisfaction.

Power-on Silence: the unit will not sound when power is initially supplied

Perfect Mount System includes a gasketless base for easy installation and a new mounting bracket that keeps the alarm secure over a wide rotation range to allow for true alignment.

Improved UV Resistance keeps the alarm from discoloring over time.

Other Contractor Preferred Features include tamper resistant locking pins for the battery drawer and mounting bracket, dust cover, universal mounting bracket with large opening and multiple keyhole slots, side load battery drawer with battery pull tab and AC quick connect power connector.





BRK 9120 Series Alarms Introduction and Frequently Asked Questions

New Part Number: 9120 Series.

Question: What will the 9120 Series replace?

Answer: The 9120 Series will replace all 4120 Series smoke alarms and the SC6120B smoke/CO combo alarm as per the table below:

| Current # | New # | Description |
|-------------|-------------|---|
| 4120 | 9120 | AC BRK Smoke |
| 4120-12ST | 9120-12ST | AC BRK Smoke in 12-pack Stadium Tray |
| 4120AB | 9120AB | AC/DC BRK Smoke w/Alkaline Battery |
| 4120B | 9120B | AC/DC BRK Smoke (includes silence) |
| 86RACHA | 9120BA | AC/DC BRK Smoke-Canada |
| 4120B-48B | 9120B-48B | AC/DC BRK Smoke 48 bulk pack |
| 4120B-48P | 9120B-48P | AC/DC BRK Smoke 48 pack |
| 4120B-GFD | 9120B-GFD | AC/DC BRK Smoke Gravity Feed Display |
| 4120LB | 9120LB | AC/DC BRK Smoke w/Lithium Battery |
| 4120SAB | Obsolete | Not needed-Silence is a standard feature |
| 4120SB | Obsolete | Not needed-Silence is a standard feature |
| 4120SB-12ST | 9120B-12ST | AC/DC BRK Smoke 12 pack Stadium Tray |
| 4120SB2 | 9120B2 | AC/DC BRK Smoke 2 pack |
| 4120SB-48B | Obsolete | Not needed-Silence is a standard feature |
| 41206CP | 91206CP | AC BRK Smoke Contractor bulk 6-pack |
| 4120SB6CP | 9120B6CP | AC/DC BRK Smoke Contractor bulk 6-pack |
| 4120SB-GFD | Obsolete | Not needed-Silence is a standard feature |
| 4919A | 9120A | AC BRK Smoke Canada |
| 8120BL | Obsolete | Not needed. Latching is a standard feature. |
| SA4120B-48B | SA9120B-48B | AC/DC First Alert Smoke 48 bulk pack |
| SA4120CN | Obsolete | AC First Alert Smoke-clamshell |
| SA4121B-48B | Obsolete | Not needed-Silence is a standard feature |
| SA4121CN | SA9121CN | AC/DC First Alert Smoke-clamshell 3-pack |



BRK 9120 Series Alarms Introduction and Frequently Asked Questions

| Current # | New # | Description |
|--------------|--------------|---|
| SC6120B | SC9120B | AC/DC BRK Smoke/CO combo |
| None | SC9120B-GFD | AC/DC BRK Smoke/CO Gravity Feed Display |
| None | SC9120BA | AC/DC BRK Smoke/CO combo-Canada |
| SC6120B-12ST | SC9120B-12ST | AC/DC BRK Smoke/CO combo-12-pack stadium tray |
| SA4121CN3 | Obsolete | Replaced by SA9121CN |

Question: What's "Smart Technology"?

Answer: "Smart Technology" is a system of improvements designed to work together to reduce nuisance alarms. The 9120 Series smoke alarms have a new metal sensing chamber that better insulates the sensor from certain transients (dirty power) transmitted over standard AC house wiring from the power companies. A redesigned cover top and underneath help to better channel smoke to the sensing chamber and improve horn output. A new integrated circuit (IC) or brains of the alarm takes multiple looks at conditions that cause the unit to alarm (due to either emergency or non-emergency conditions) versus only once with the 4120 series. This happens before going into alarm, thus reducing the tendency to "nuisance" alarm. **Special Note:** The SC9120B use a microprocessor vs. an IC as the brains for the alarm and therefore does not utilize "Smart Technology" or have a metal chamber. The SC9120B utilizes Intelligent Sensing Technology™ to achieve similar results.

Question: What happens upon initial power-up or during a loss of power to the 9120 Series Alarm?

Answer: The 9120 series alarm will remain silent upon initial power-up as long as the battery pull tab is removed prior to AC power being applied. No more alarms or chirps as with the 4120 series. This is especially important after a unit is



THE REVOLUTION
Faster, Better
Smarter

BRK 9120 Series Alarms Introduction and Frequently Asked Questions

in operation and there is a loss of power. Previously, the 4120B might go into alarm upon power-up. The new 9120B will remain silent. Note: If AC power is supplied before battery tab is removed, the unit is performing a normal battery test function and will chirp twice in the first 5 - 10 seconds.

Question: What's different about the "Perfect Mount" mounting system?

Answer: The 9120 Series mounting system has been completely redesigned based on our customers' comments. The main difference is that the gasket has been removed. This allows for easier installation. In addition, the alarm will remain secure over a wide rotation range to allow for perfect alignment. The alarm can be rotated past 12:00. When wall mounting, this will allow fine-tuning on the positioning to compensate for out of aligned wall studs and to keep the wording level. The alarm can be positioned over the bracket every 120°. The features that pioneered the industry when the 4120B was introduced have remained. The large holes in the mounting bracket and keyhole slots have been retained.

Question: Can the 9120 Series alarm fit on the 4120 series mounting bracket?

Answer: No. The enhanced alignment features and gasketless base will not allow the 9120 to mount on the old 4120 mounting bracket. However, as with the 4120 series alarms, installation and removal of the mounting bracket is easy with the keyhole slots. The mounting screws do not have to be fully removed. Just back off slightly and twist the bracket to loosen. Then replace with the new 9120 series bracket. The quick-connect power connector is common to all BRK and First Alert hardwired alarms. Therefore, to replace a 4120 series with a 9120 series alarm, all that needs to be done is change the mounting bracket.





BRK 9120 Series Alarms Introduction and Frequently Asked Questions

Question: Is the 9120 Series alarm interconnectable with other BRK/First Alert alarms?

Answer: Yes. The 9120 Series is interconnectable with all current BRK and First Alert hardwired smoke, carbon monoxide, heat, hearing impaired alarms and relays. It is interconnectable with up to 18 devices (smoke, carbon monoxide, heat alarms and relays, etc.), 12 of which can be smoke alarms as outlined by NFPA.

Question: How do I test the 9120 Series Alarm?

Answer: The Single Button Test/Silence feature makes it easy to test the alarm individually and when interconnected. **Single Station Alarms:** Test each smoke alarm. Press and hold the Test/Silence button until the unit alarms. **Alarms in an Interconnected Series:** Press and hold the Test/Silence button until the unit alarms (about 3 seconds). All interconnected alarms should sound. **Important Note:** Only the interconnect signal is tested on the other alarms. It does not test each alarm's chamber operation. **You must test each alarm individually to check if the alarm is functioning properly.** This is true of all UL listed smoke alarms.

Key Note: Different from the 4120 series, the 9120 series alarms will stop testing immediately upon releasing the test button. This improvement was added to make it easier for inspectors and homeowners to silence the unit quicker. No more going through a complete horn pattern after the button is released.

Question: What visual indications do I get during testing of an alarm?

| | |
|--------------------------------|---------------------------------|
| Answer: On tested alarm | Red LED flashes rapidly |
| On all other alarms | Green LED(s) on, Red LED is off |





BRK 9120 Series Alarms Introduction and Frequently Asked Questions

Question: How do I silence smoke alarms in an interconnected series:

Answer: Whether with the 9120 Series or other BRK/First Alert smoke alarms, to silence multiple alarms in an interconnected series, you must press the Test/Silence button on the unit(s) that triggered the alarm.

Note: The red LED on the initiating alarm will flash rapidly. The red LED will be off on all other non-initiating alarms. **New on the 9120 series is that no periodic audible chirp will be heard after the unit is silenced.** The unit will exit "silence mode" in approximately 10 minutes. While the unit is in "silence mode" pressing and holding the Test/Silence button for approximately 10 seconds will test the unit. After testing, the unit will re-enter "silence mode" and the 10-minute timer will start over.

Question: How does the "Latching Alarm Indicator" work on the 9120 Series alarms?

Answer: On the 9120 Series Smoke Alarms the "Latching Alarm Indicator" is automatically set when an alarm is initiated. When the alarm condition has subsided the "Latching Alarm Indicator" is set only on the alarm(s) subjected to the nuisance issue. This feature improves homeowner satisfaction by allowing for easy contractor troubleshooting of nuisance alarms with minimal time in the home. No more wasted time and money removing all alarms to resolve a homeowner's concern. The green LED indicator will be on for two seconds/off for two seconds, repeatedly until pushing the Test/Silence button resets the "Latching Alarm Indicator".

After an Alarm (Latching):

| | |
|------------------------|--|
| On initiating alarm(s) | Green LED on for 2 seconds/off for 2 seconds |
| On all other alarms | Green LED on, Red LED is off |

The SC9120B is slightly different from the 9120 Series and has not changed from the current SC6120B. The alarms latch in the same manor. That is, when an event triggers an alarm; however the light indicators are different.



BRK 9120 Series Alarms Introduction and Frequently Asked Questions

After the alarm has "latched", the red LED will flash once every 5 seconds on either the Smoke side, CO side or both, depending on whether smoke, CO or both events have occurred. To clear the "latch" press the Test/Silence" button.

After an Alarm (Latching):

| | |
|------------------------|----------------------------------|
| On initiating alarm(s) | Red LED(s) flash every 5 seconds |
| On all other alarms | Green LED on, Red LED is off |

Question: Is the 9120 UL approved?

Answer: Yes. 9120 series smoke alarm meets UL 217 for smoke alarms and SC9120B meets both UL217 and UL2034 for CO alarms. These alarms also comply with California State Fire Marshall (CSFM), Federal Housing Authority (FHA), Housing and Urban Development (HUD), National Fire Protection Agency (NFPA) and New York City (MEA).



Question: Does the 9120 have tamper resistant features?

Answer: Yes. The 9120 Series has two locking features. One to lock the unit to the mounting bracket and one to lock the battery drawer (except 9120 AC only unit).

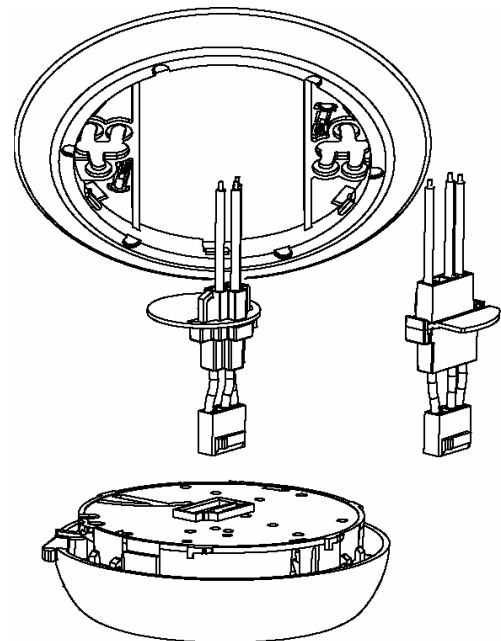

Question: Can I use the First Alert Universal Adapter Plugs with the 9120 Series?

Answer: Yes. Both of the First Alert adapter plugs (ADK-12) for Kidde and (ADF-12) for Firex alarms have been approved and will work with the 9120 series alarms. The universal adapter plugs allow the connection of



BRK 9120 Series Alarms Introduction and Frequently Asked Questions

BRK and First Alert hardwired alarms to either Kidde/Fyrnetics or Firex brand hardwired alarms without disconnecting the wires. This is an advantage for retrofitting and maintenance replacement jobs. Saves time and money.

Question: What other "Contractor Preferred" features does the 9120 Series product line have?

Answer: A Dust Cover is included to keep the alarm clean during construction. Also the same easy Installation/maintenance Features pioneered on the 4120 series have been retained:

- Universal bracket works with any standard electrical box up to 4" in size.
- A large opening in the mounting bracket for easy access to wiring.
- A battery pull-tab that keeps battery fresh until the home is occupied.
- A Side Load Battery Drawer allows for easy battery installation/replacement without removing the alarm from the ceiling or wall. (Model 9120B and SC9120B only).
- AC Quick-Connect Power connector
- Keyhole slots in mounting bracket eliminate the need to completely remove the mounting screws from the electrical box to install the bracket.

Question: How long will the battery last under battery backup?

Answer: A fresh battery in the 9120B will last up to one year, depending on how old it was before it was installed and when it was activated. UL 217 mandates that the battery in a backup mode only need to last for 24 hours in standby condition and thereafter be able to be in alarm for at least 4 minutes.

The SC9120B battery will last for about 20 to 30 days. UL 2034 states that the battery should last for 7 days in standby condition and thereafter be able to be in alarm for at least 4 minutes.





BRK 9120 Series Alarms Introduction and Frequently Asked Questions

Question: Does the 9120 Series plastic have UV protection?

Answer: Yes. The plastics have been enhanced to include Ultraviolet protection to help keep the unit from discoloring after prolonged exposure to UV rays. This can occur if the unit is exposed to the direct rays of the sun, near fluorescent lighting or other UV sources. Positioning near a skylight or large window can allow the sun to shine directly on the unit for a period of time during the day.

Question: How does the 9120B stack up against the competition?

Answer: FIREX[®]

AC Alarms:

406/41216/428

AC/DC Alarms:

4418/4518: This has turned into the price point alarm for Firex. It is an older model lacking many of the expected features by contractors. The 4518 has silence.

- Separate model for Silence
- This still has the battery replacement in the back of the unit. The battery is shipped backwards from the factory so additional labor must be used to re-insert the battery properly.
- The mounting bracket is difficult to use and does not adjust.
- No Latching
- The battery drawer cannot be locked separately from the alarm lock.
- No battery pull tabs

4618: This is Firex's newer model designed to compete with BRK's 4120B. It has added the top load battery drawer.

- No Latching indicator
- Mounting bracket is not adjustable.
- The battery drawer cannot be locked.



BRK 9120 Series Alarms Introduction and Frequently Asked Questions

- Single button test/silence.
- Battery pull-tab.

5000: The 5000 has Latching added.

- Latching mode is very difficult to distinguish from Silence mode and low battery. Latching: RED light blinks 3 times every minute, Silence: RED light blinks once every 10 seconds and low battery: RED light blinks 4 times every minute.
- Mounting bracket is not adjustable.
- The battery drawer cannot be locked.
- Single button test/silence.
- Battery pull-tab.
- Ramp-up test horn sounds like unit is mal-functioning with its variable sound output.

KIDDE®/FYRNETICS®

AC Alarms: 1235

- No model with Silence

AC/DC Alarms: 1275/1275EH: These were Kidde's staple models for AC alarms. They will be replaced by the 1276. These models do have latching but are in a housing that is missing most of the current contractor preferred features:

- Separate model for Silence
- The battery is accessed from the back of the unit
- The mounting bracket is not user friendly

1276: This is the latest introduction from Kidde. They have addressed many of the shortcomings from the old lineup. They almost match up feature for feature with the new 9120B. They do have two separate buttons for test and silence.



THE REVOLUTION
Faster, Better
Smarter

BRK 9120 Series Alarms Introduction and Frequently Asked Questions

USI[®]

AC Alarms: 1213

AC/DC Alarms: 1204/1209: The 1204/1209 alarms are on an old USI platform that is missing most of the current contractor preferred features:

- Mounting bracket is most difficult to use in the industry. The keyhole slots are covered by foam and are very difficult to locate on the electrical box. Also, it's not adjustable.

- Separate model for Silence

- No Latching

- The battery drawer cannot be locked separately from the alarm lock.

- Single button test/silence on 1204

5204: The USI 5204 is the latest USI model which added a side load battery drawer

- No Latching

- The battery drawer cannot be locked.

- Single button test/silence.

Question: How much more will we charge for all of these features?

Answer: Nothing! All of these features, Latching, Silence, Smart Technology, Gasketless Base, Perfect Mount System, etc. are at no additional charge from the current pricing of the 4120B. This will allow us to have a tremendous advantage in the marketplace.



SMOKE ALARMS

CO ALARMS

HEAT ALARMS

FIRE EXTINGUISHERS